



JOB: _____

CONTRACTOR: _____

P.O. NO. _____

FIBERGLASS HANGER

ISOLATOR TYPE	COLOR	RATED LOAD	RATED DEFL.
1FG	WHITE	100#	0.25"

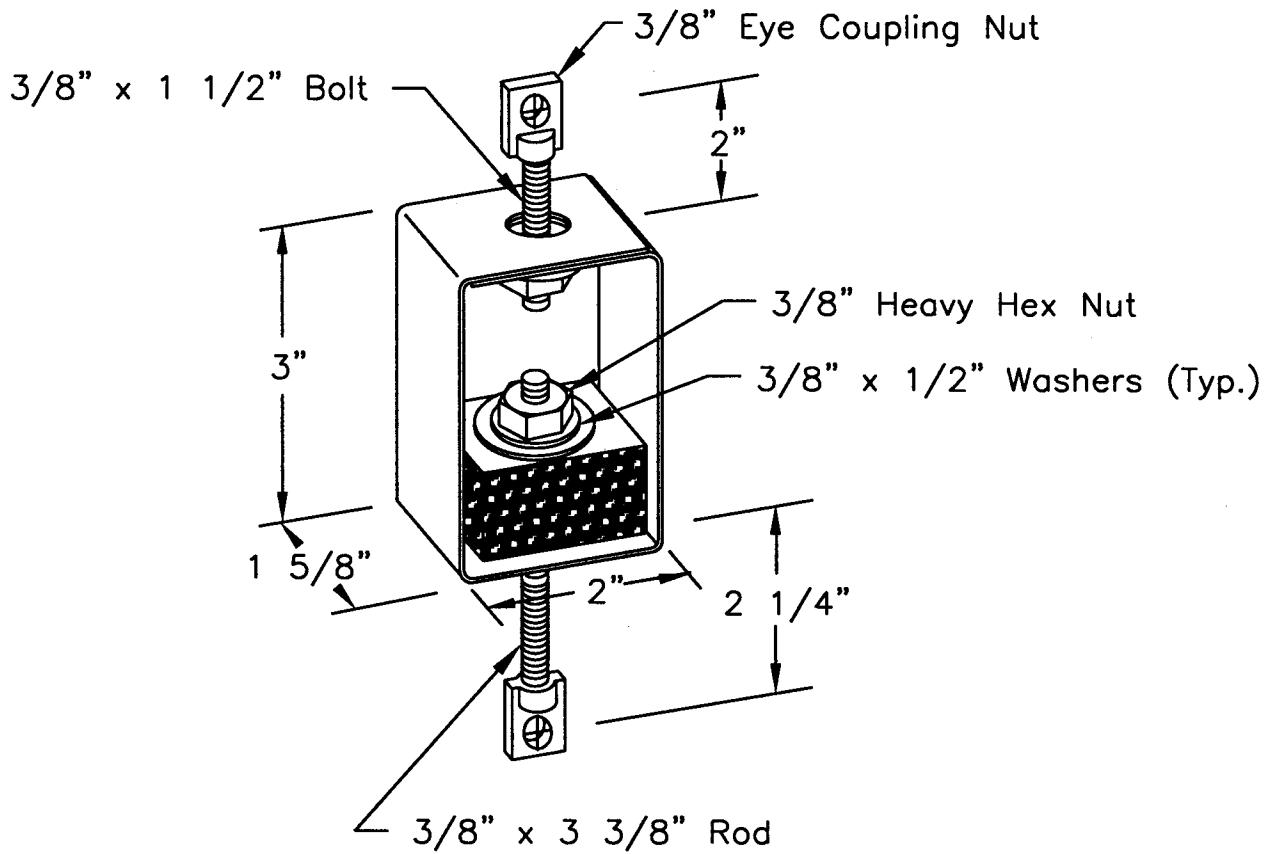

VIBRATION ELIMINATOR CO., INC.

15 Dixon Avenue
Copiague, NY 11726

TEL. (631) 841-4000 FAX (631) 841-0020

Rev.		
Rev.		
Date:	Dwg. No.:	