

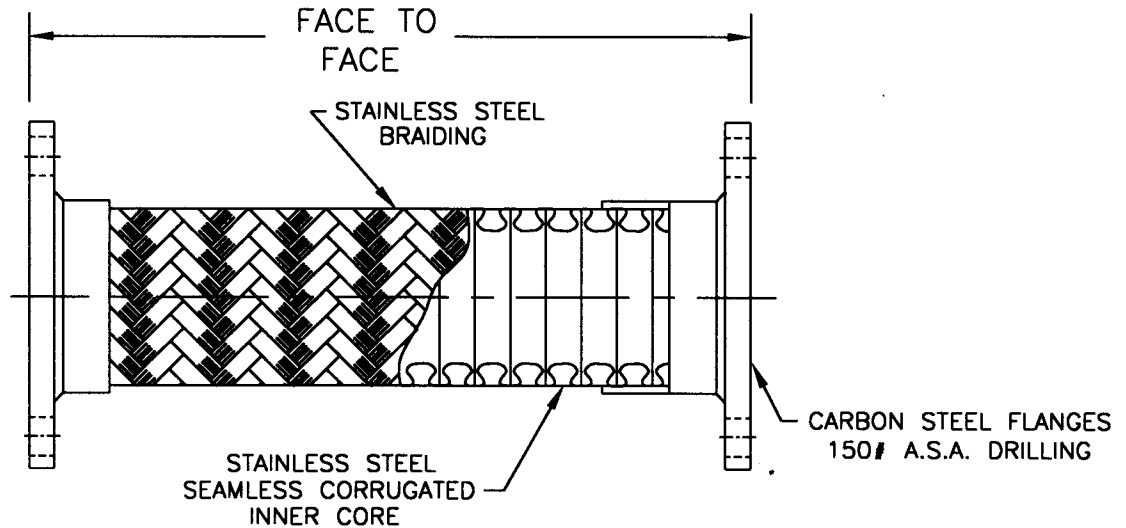

JOB: \_\_\_\_\_  
 CONTRACTOR: \_\_\_\_\_  
 P.O. NO. \_\_\_\_\_

V.E. DWG. NO.  
 \_\_\_\_\_

## STAINLESS STEEL FLEXIBLE CONNECTORS



**NOTES:**

1. NOT INTENDED FOR USE WITH VITAULIC FLANGE.
2. 1/8" MAXIMUM OFFSET MOTION.
3. LONGER LENGTHS AVAILABLE UPON REQUEST.

QTY.	PIPE SIZE	FACE TO FACE	WORKING PRESSURE @ 70°F	TAG
	2"	9"	400	
	2 1/2"	9"	285	
	3"	9"	240	
	4"	9"	260	
	5"	11"	220	
	6"	11"	200	
	8"	12"	190	
	10"	13"	165	
	12"	14"	125	
	14"	14"	125	
	16"	14"	125	

FOR SAFE WORKING PRESSURE ABOVE 70°F, MULTIPLY PRESSURE SHOWN AT 70°F TIMES CORRECTION FACTOR OF REQUIRED TEMPERATURE.

FOR TEMPERATURE ABOVE 70°F	
TEMP. °F	FACTOR
70	1.00
200	.94
300	.88
400	.84

FL-CONNECTOR2.DWG.