

MODEL "VE-A" ALL DIRECTIONAL ANCHOR

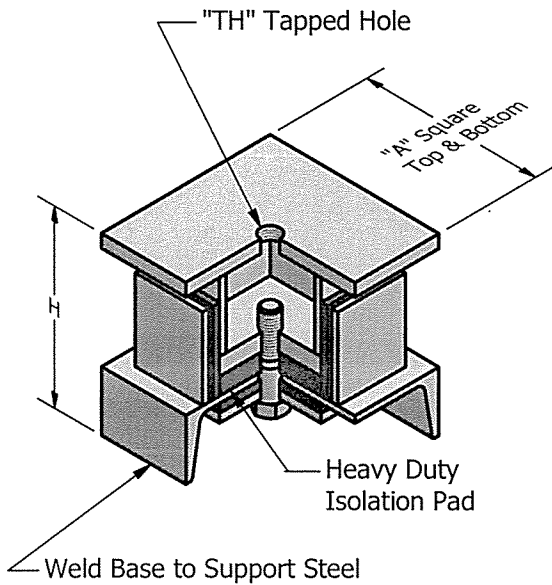

MODEL	A	H	TH	Capacity per Pair	Rated Defl.
VE-A1K	3	4 1/4	3/8-16UNC	700#	0.1"
VE-A3K	3	4 1/4	3/8-16UNC	3,000#	0.1"
VE-A4K	5	5	1/2-13UNC	8,000#	0.1"
VE-A8K	6	5	1/2-13UNC	16,000#	0.1"
VE-A15K	8	8	5/8-11UNC	30,000#	0.1"

Each pair of all directional anchors provides high frequency noise and vibration isolation for those locations where movement must be controlled.

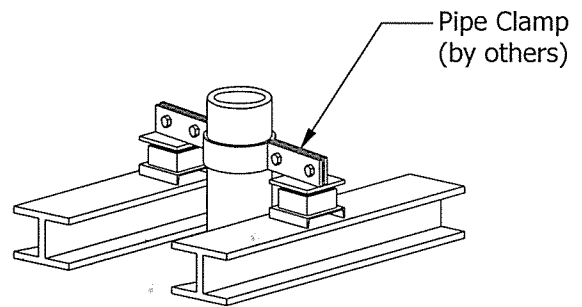

Isolation Pad Physical Properties

Tensile Strength 1,000 p.s.i. min.
 Compressive Strength 10,000 p.s.i. min.
 % Elongation 100 max.
 Durometer (Shore A) 80 ± 5
 Tear Strength 600 lb. min.
 (Whith Grain and Across Grain)
 Abrasion Resistance00012
 (Grams/Rev. Max. Surface Removal)

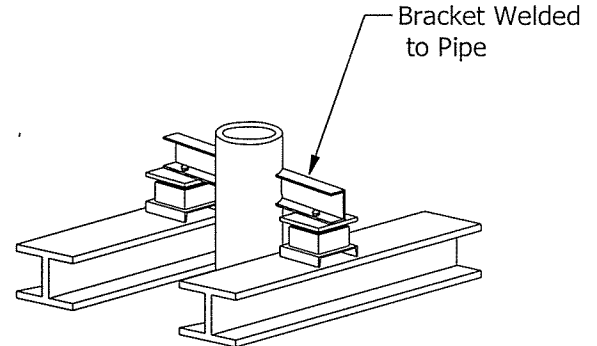

JOB: _____
 CONTRACTOR: _____
 P.O. NO.: _____

Vibration Eliminator Co., Inc.
 15 Dixon Avenue, Copiague NY 11726
 Tel. (631)841-4000 Fax (631)841-0020

DWG. #